

REVISIONS			
REV.	DESCRIPTION	DATE	APPROVED
-		12/11/2023	

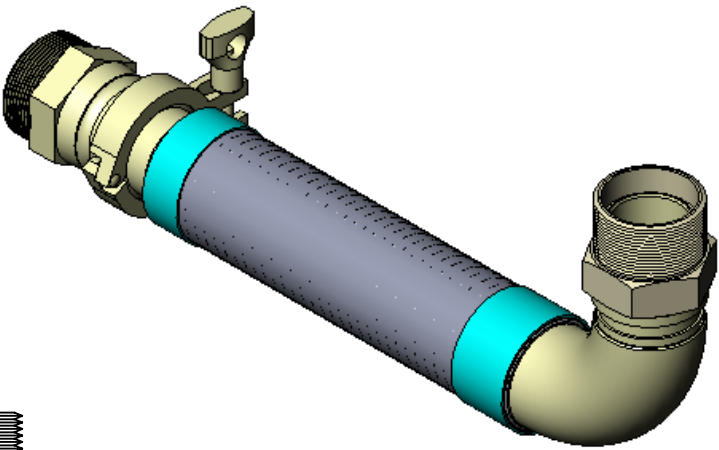

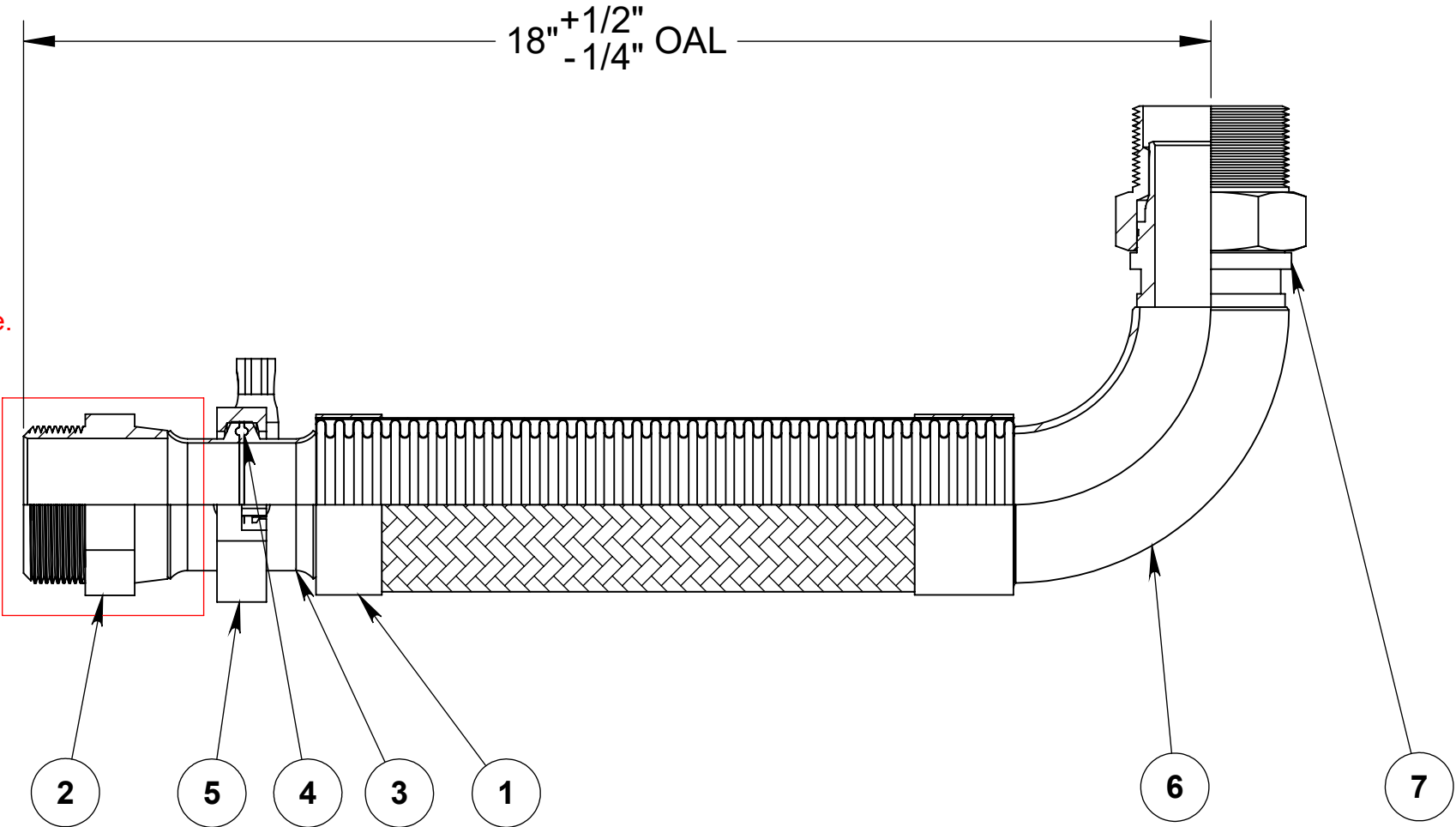

Hex male adapter shown represents only one of the various end fittings available. Please refer to the catalog for other options.



- NOTES:**
1. UL & cULus APPROVED CONNECTORS
  2. OAL IS MEASURED FROM THE CENTERLINE TO THE END OF THE SELECTED FITTING

----- COMPONENTS LIST -----

ITEM #	QTY.	DESCRIPTION	MATERIAL
1	1	2" AF4750	300 Series Stainless
2	1	2" Hex Male Adapter	304
3	1	2" Sanitary Flange	304
4	1	2" QuickClamp Seal	Viton
5	1	2" Quick Clamp Kit	304
6	1	Elbow, Sched 40/STD, 90 Deg, Long Radius, 2.00"	304
7	1	FireShield 2" Male Swivel, 2"x11-1/2" Thread, 2.38" Hex	304

	<b>HOSE MASTER</b> 1233 East 222nd Street • Cleveland, Ohio 44117 (800) 221-2319 • Fax: (216) 481-7557 • www.hosemaster.com <b>Cleveland • Houston • Atlanta • Reno</b>	<b>ISO 9001</b> Registered Quality System 
	DESCRIPTION: <b>2" FIRESHIELD QUICKCLAMP ASSEMBLY</b>	DATE: 12/13/2023 PROJECTION: 
DRAWING # <b>FSQSE0200x18</b>	REV. <b>-.01</b>	SHEET <b>1 OF 1</b>

REVISIONS			
REV.	DESCRIPTION	DATE	APPROVED
-		12/11/2023	

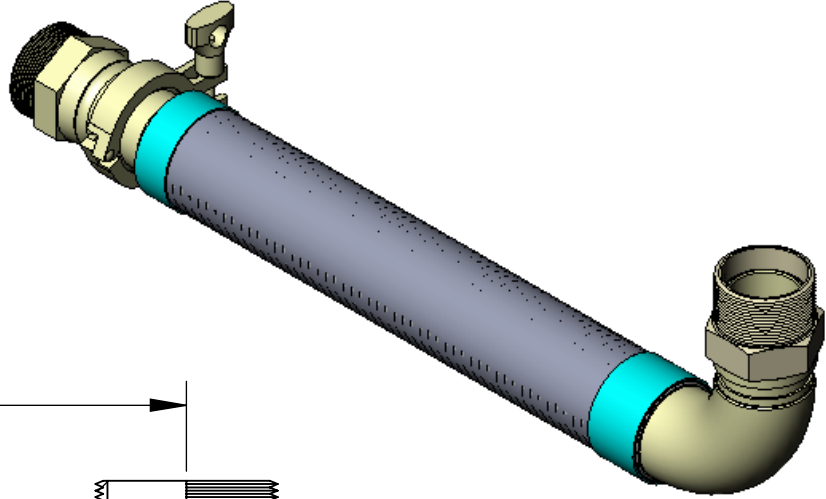

24" <sup>+1/2"</sup> <sub>-1/4"</sub> OAL

Hex male adapter shown represents only one of the various end fittings available. Please refer to the catalog for other options.

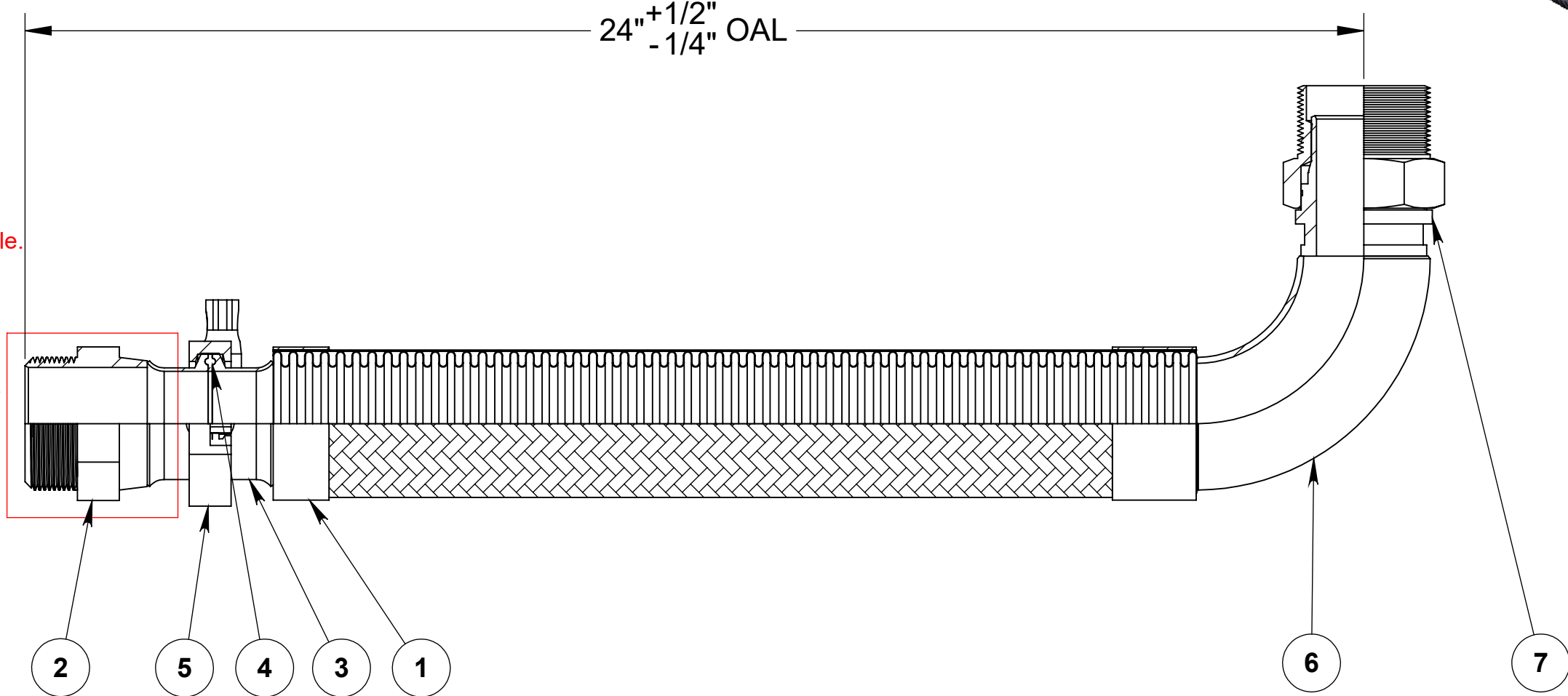

- NOTES:**
1. UL & cULus APPROVED CONNECTORS
  2. OAL IS MEASURED FROM THE CENTERLINE TO THE END OF THE SELECTED FITTING

----- COMPONENTS LIST -----

ITEM #	QTY.	DESCRIPTION	MATERIAL
1	1	2" AF4750	300 Series Stainless
2	1	2" Hex Male Adapter	304
3	1	2" Sanitary Flange	304
4	1	2" QuickClamp Seal	Viton
5	1	2" Quick Clamp Kit	304
6	1	Elbow, Sched 40/STD, 90 Deg, Long Radius, 2.00"	304
7	1	FireShield 2" Male Swivel, 2"x11-1/2" Thread, 2.38" Hex	304



**HOSE MASTER**

1233 East 222nd Street • Cleveland, Ohio 44117  
 (800) 221-2319 • Fax: (216) 481-7557 • www.hosemaster.com  
 Cleveland • Houston • Atlanta • Reno

ISO 9001  
Registered Quality System



DESCRIPTION:  
**2" FIRESHIELD QUICKCLAMP ASSEMBLY**

DATE: 12/13/2023

PROJECTION:



DRAWING #

**FSQSE0200x24**

REV.

**-.01**

SHEET  
1 OF 1

REVISIONS			
REV.	DESCRIPTION	DATE	APPROVED
-		12/11/2023	

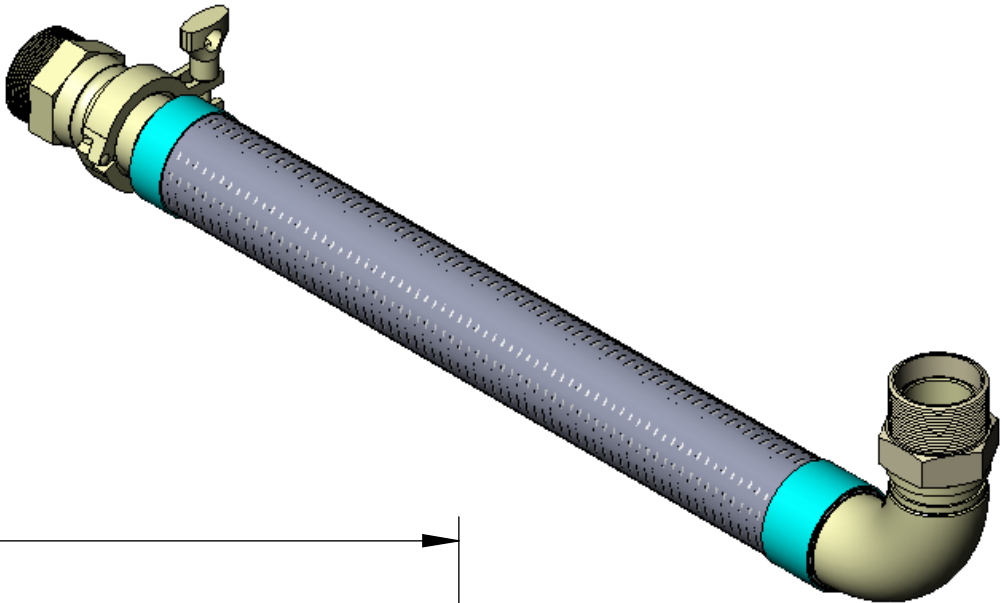

24" +1/2"  
- 1/4" OAL

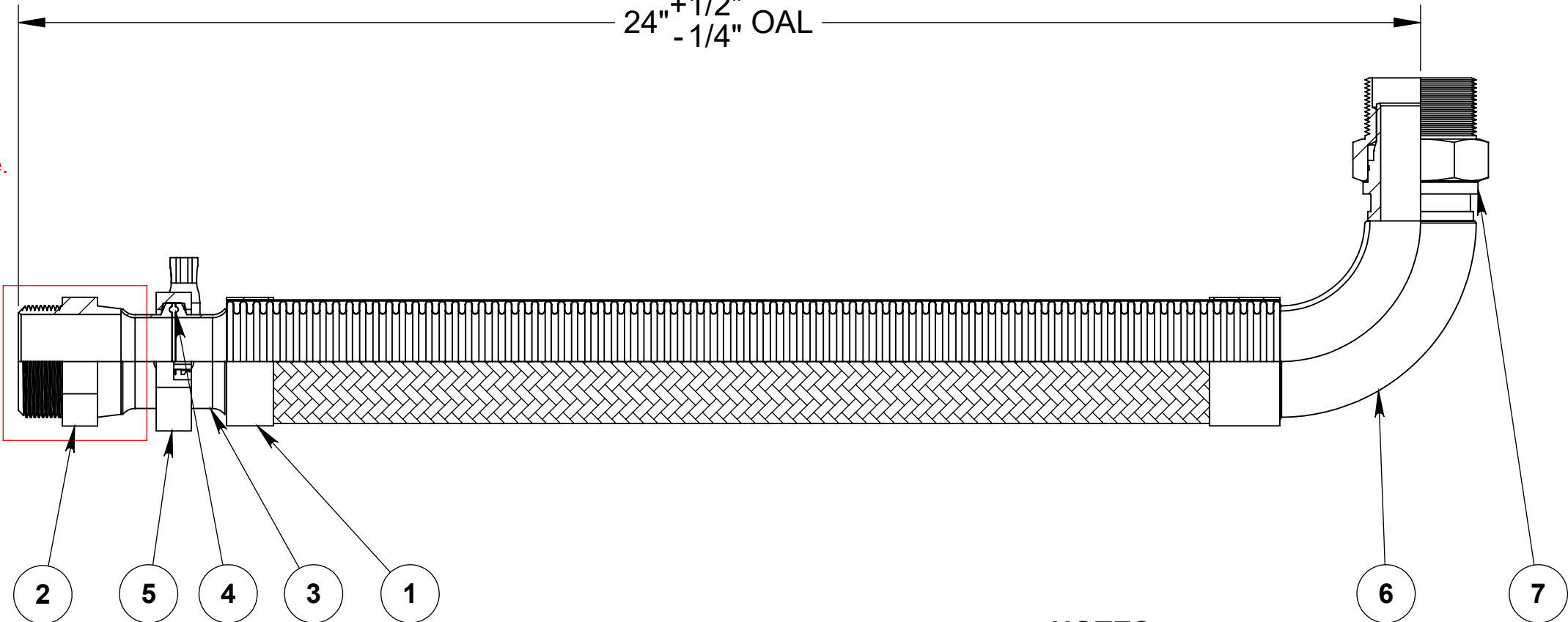

Hex male adapter shown represents only one of the various end fittings available. Please refer to the catalog for other options.



- NOTES:**
1. UL & cULus APPROVED CONNECTORS
  2. OAL IS MEASURED FROM THE CENTERLINE TO THE END OF THE SELECTED FITTING

----- COMPONENTS LIST -----

ITEM #	QTY.	DESCRIPTION	MATERIAL
1	1	2" AF4750	300 Series Stainless
2	1	2" Hex Male Adapter	304
3	1	2" Sanitary Flange	304
4	1	2" QuickClamp Seal	Viton
5	1	2" Quick Clamp Kit	304
6	1	Elbow, Sched 40/STD, 90 Deg, Long Radius, 2.00"	304
7	1	FireShield 2" Male Swivel, 2"x11-1/2" Thread, 2.38" Hex	304

	<b>HOSE MASTER</b> 1233 East 222nd Street • Cleveland, Ohio 44117 (800) 221-2319 • Fax: (216) 481-7557 • www.hosemaster.com <b>Cleveland • Houston • Atlanta • Reno</b>	<b>ISO 9001</b> Registered Quality System 
	DESCRIPTION: <b>2" FIRESHIELD QUICKCLAMP ASSEMBLY</b>	DATE: 12/13/2023 PROJECTION: 
DRAWING # <b>FSQSE0200x30</b>	REV. <b>-.01</b>	SHEET <b>1 OF 1</b>